

A		旋台直徑 Worktable diameter	ø170 mm	
A		中心孔直徑 Center bore diameter	ø40H7	
B		工作台高度 Height of table	260 mm	
B		中心高度 Height of center	190 mm	
B		工作台T型槽寬度 Width of T-slot	12H7 mm	
C		最大工件負載 MAX. loading capacity	50kg(In horizontal)/35kg(In tilt)	
C		軸向 Axis	旋轉軸 Rotary	傾斜軸 Tilt
C		伺服馬達型式 (選配) Servo motor	FANUC	A4I
C			MITSUBISHI	HF54T
C			PANASONIC	102S1
D		齒數比 Transmission ratio	1:90	1:90
D		最高迴轉數 MAX. table speed	33.3 rpm	22.2 rpm
E		最小設定單位 Resolution	0.001°	
E		分度精度(光學尺) Indexing accuracy	20°	60°
E		重複精度 Repeatability	6°	8°
F		可傾斜角度 Tilting angle range	+30° ~ -120°	
F		剎車鎖緊力 Clamping torque	18 Kg-m	26 Kg-m
F		容許切削扭矩 Allowable cutting torque	17 Kg-m	
G		氣壓剎車源 Pne pressure	5 Kg/cm ²	

客戶確認用章 Customer confirmation	
核准 Approbation	審核 Audit

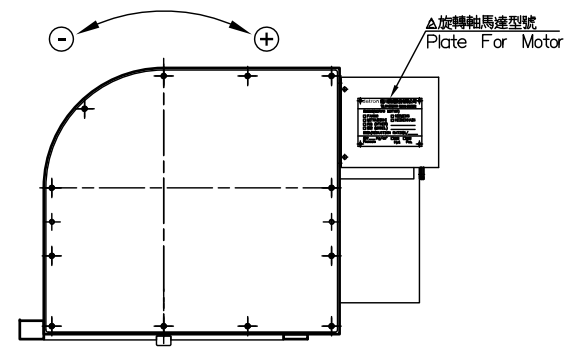
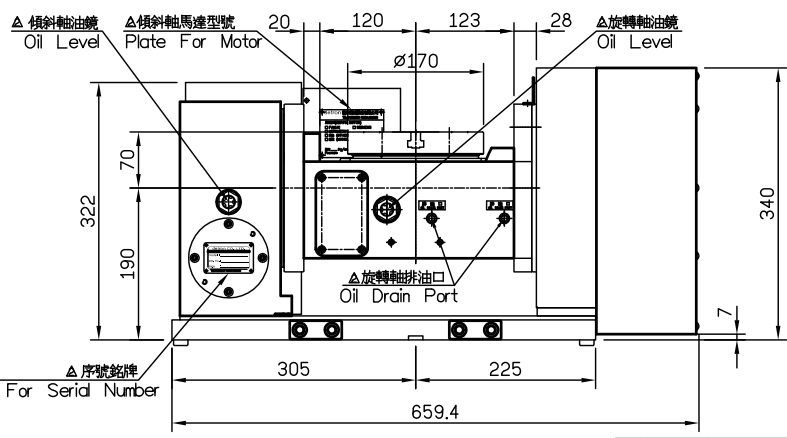
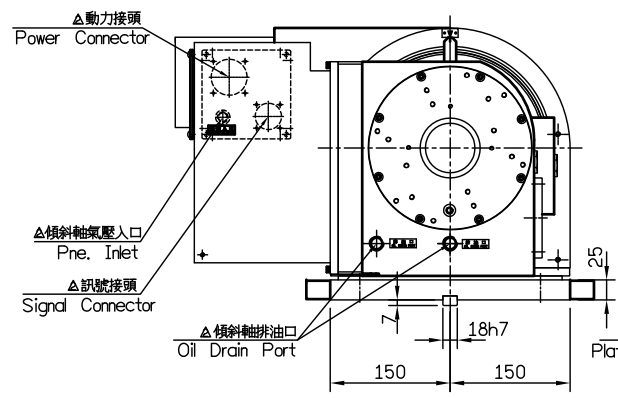
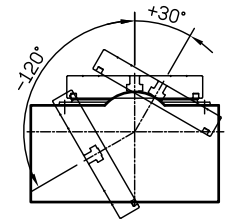
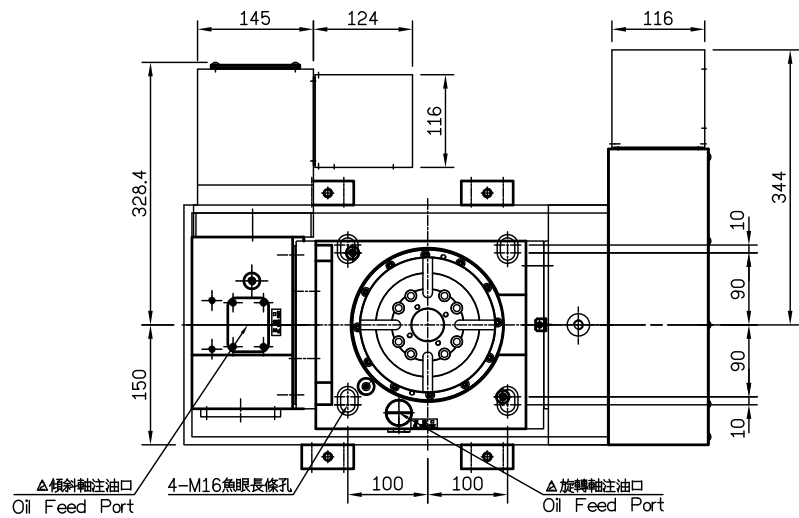
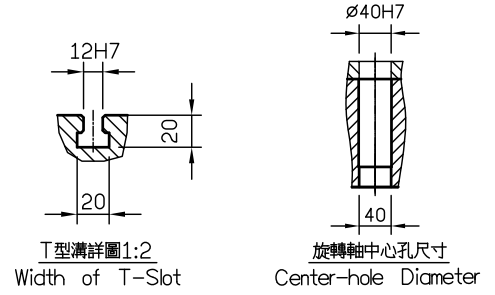
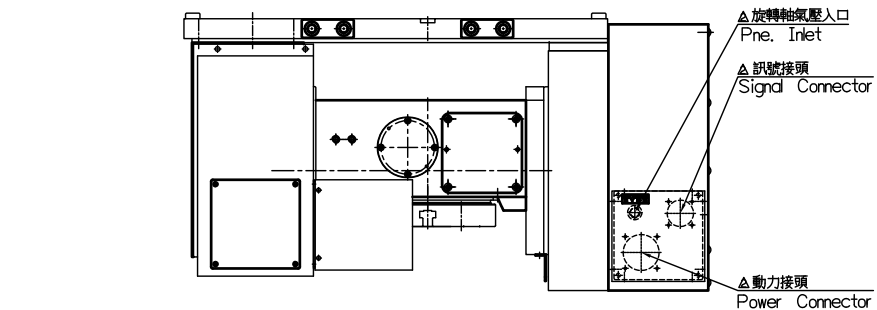

比例 SCALE		圖號 MODEL		材質 MATERIAL		名稱 TITLE		料號 PART NO.	
1=5		GF170P		五軸加工機		GF170P-A02			
角法 SKIAGRAPHY		單位 UNIT		備註 REMARKS		校準		繪圖	
26'05'11		1/台							
ITEM DATE		ITEM DESCRIPTION							

1/5 (0.4)^G