

1 2 3 4 5 6 7 8 9 10 11 12 13 14 15

| | | | |
|--|-----------------------|---|---------|
| 工作台尺寸 Palet dimension | 800x800 mm | T型槽寬 Width of T-slot | 22H7 |
| 中心孔尺寸 Center hole diameter | ø50H7 | 盤面偏擺 Run out of table surface | 0.02 mm |
| 伺服馬達型號 (選配/optional) | FANUC MITSUBISHI | 上下平行度 Parallelism between table surface and table base | 0.02 mm |
| 伺服馬達 Servo motor | SIEMENS | 確認用圖 客戶確認用章 | |
| 減速比 Transmission ratio | 1:180 | 核准 | 審核 |
| 最高迴轉速 Max. table speed | 11.1 rpm | | |
| 最小設定單位 Resolution | 0.001° | | |
| 鎖緊扭力 Clamping torque | 520 Kg-m | | |
| 容許切削扭矩 Cutting torque | 430 Kg-m | | |
| 油壓源壓力 Hyd. pressure | 50 Kg/cm ² | | |
| 分度精度 Indexing accuracy | 15" | | |
| 重複精度 Repeatability | 6" | | |
| 容許負載容量(平均負載) Max. table load(Average) | 2000 Kg | | |
| 平臺總高度 Overall height in horizontal | 360 mm | | |

A
B
C
D
E
F
G
H
I
J

A
B
C
D
E
F
G
H
I
J

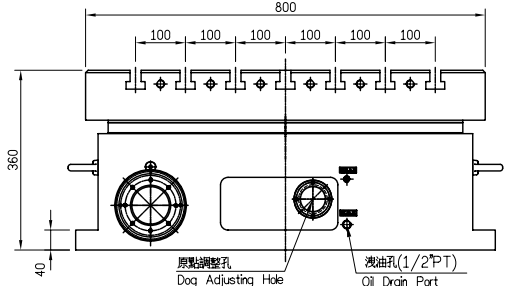
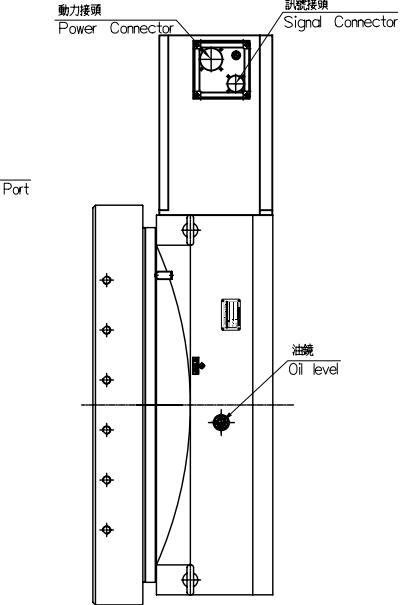
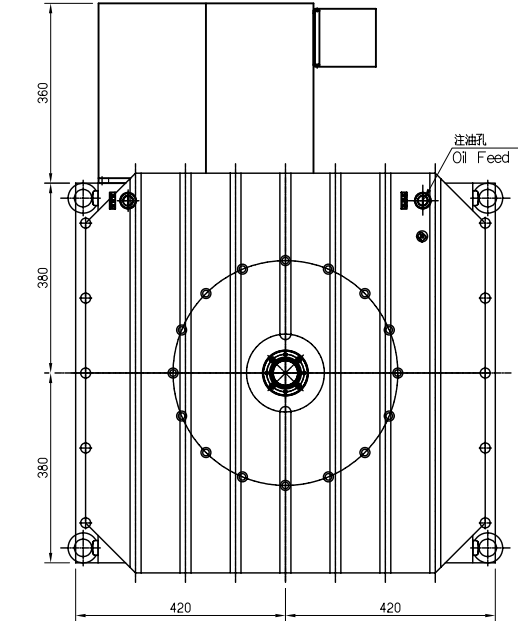
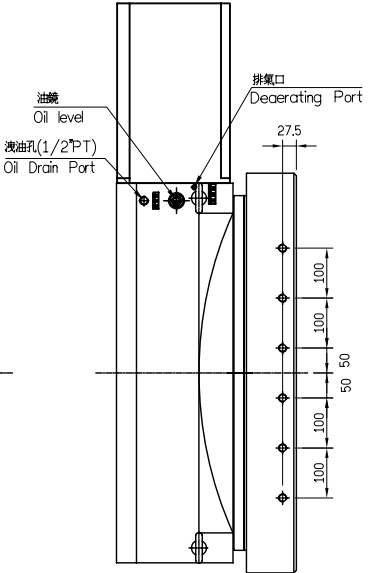
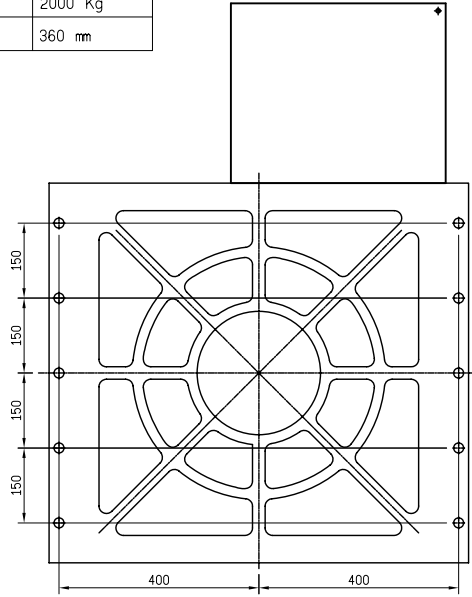

標準機編碼:GH800HT-A01

| | | | | | | | |
|-----------------------|--------------------------|----------|------------|----------|-------------|----------|----------------|
| detron | | 比例 SCALE | 1=8 | 機型 MODEL | 材質 MATERIAL | 名稱 TITLE | 圖號 DRAWING NO. |
| 角法 SKIAGRAPHY | | 用圖 UNIT | 備註 REMARKS | 快車 | 管圖 | 繪圖 | |
| △ XXXXXX ITEM DATE | XXXX ITEM DESCRIPTION | | | | | | SHEET OF A2 |

1 2 3 4 5 6 7 8 9 10 11 12 13 14 15