

MAX. Loading Capacity	Vertical 100Kg Horizontal 250Kg
Allowable loading inertia	20.7 Kg.cm.s ²
Indexing accuracy	15"
Repeatability	6"
Resolution	0.001'
Allowable cutting torque	55 kg-m
MAX. table speed	22.2 rpm
	FANUC A8i
Servo motor type	1FK7060/7063 QSY116C
Transmission ratio	1:120
Clamping torque	70 kg-m
Drive pressure	50 kg/cm ²

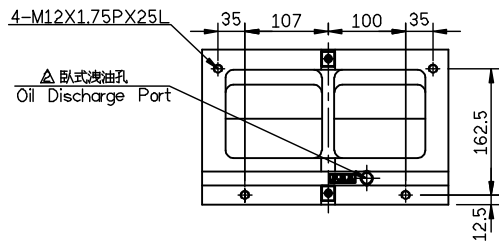
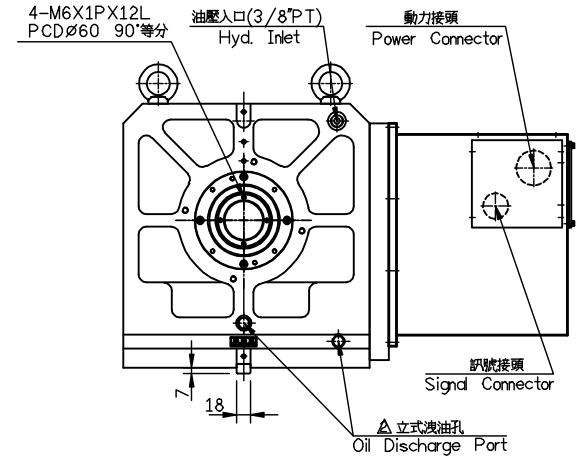
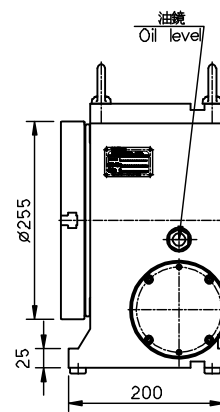
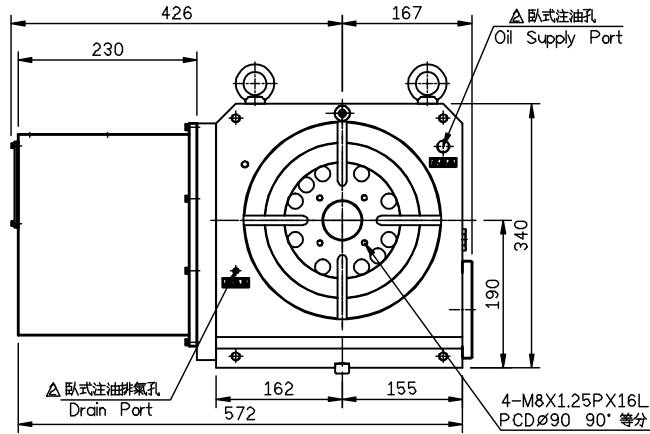
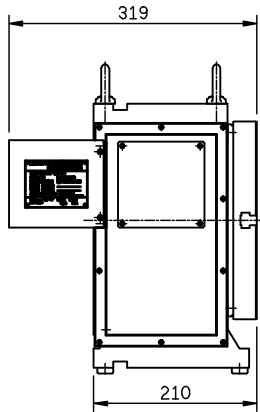
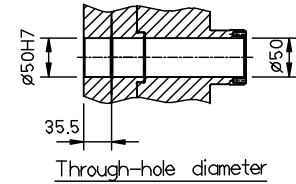
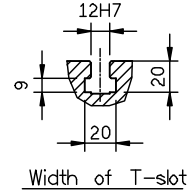
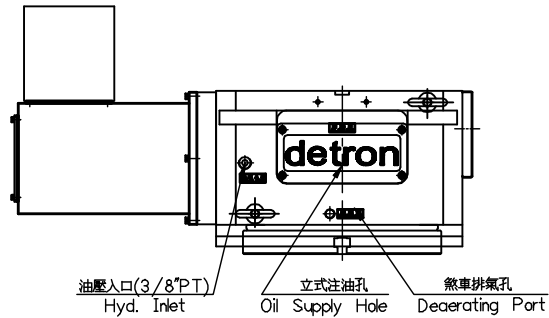

GX255HL-B02

加工一般公差	孔與孔中心距公差	表面粗糙度 4Rq=S
<6 ±0.05	<M12 ±0.1	一般標準 Ra
>6 ±0.07	>M12 ±0.2	32-125
>20 ±0.1	螺孔, 螺絲孔公差	8.0-25
>120 ±0.2		2.0-6.3
>315 ±0.3		0.25-1.6
>1000 ±0.5	角度公差 ±0.5°	0.07-0.2

		detron	比例 SCALE 1=7	機型 MODEL GX255HL	材質 MATERIAL	名稱 TITLE Dimensional Drawings	料號 PART NO.
角法 SKIAGRAPHY		用量 UNIT 1/台	備註 REMARKS	核准	審圖	繪圖	
△ 07-01-11	圖面整理, 本體油壓	◎					SHEET 1 of 1 A3
ITEM DATE	ITEM DESCRIPTION						

單號