

最大工件負載 Max Loading Capacity	立式 Vertical	50kg	伺服馬達型式: Servo motor:	HF44/75	△
	臥式 Horizontal	100kg		SGMAH04A	
許容工件慣量 Allowable Loading Inertia	2 kg-cm-sec ²		減數比 Transmission ratio	1:90	
			制車鎖緊力 Clamping torque	8 kg-m	
分割精度 Indexing accuracy	40"		氣壓制車源 Pne pressure	5 kg/cm ²	
重複精度 Repeatability	6"				
最小設定單位 Resolution	0.001°				
許容切削扭矩 Cutting torque	8.5 kg-m				
最高迴轉數 Max table speed	44.4 rpm				

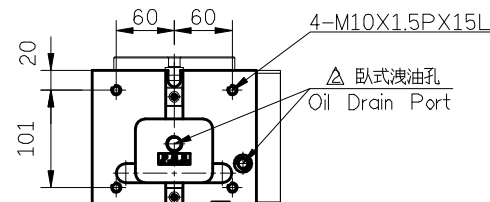
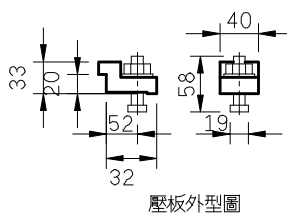
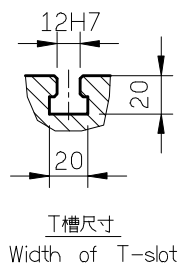
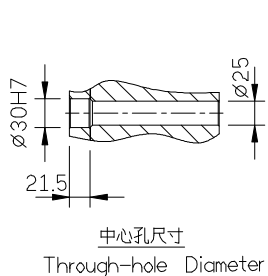
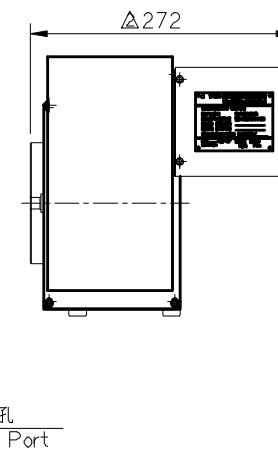
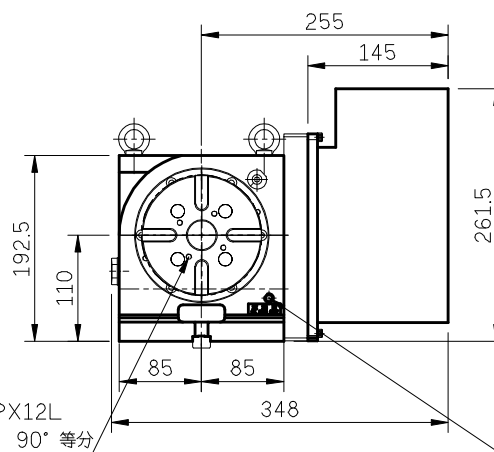
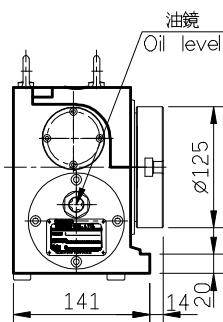
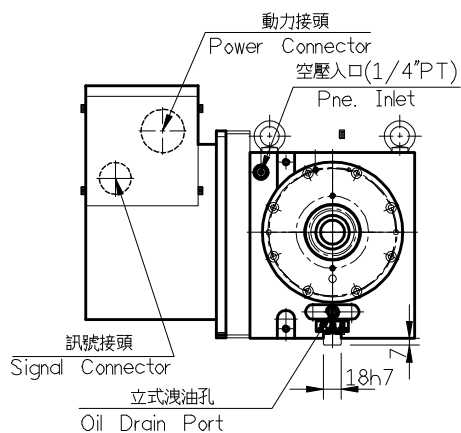
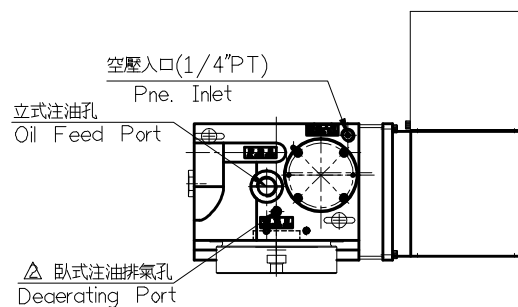

GX125P-A02

加工一般公差 <6 ±0.05 >6 ±0.07 >20 ±0.1 >120 ±0.2 >315 ±0.3 >1000 ±0.5	孔與孔中心距公差 <M12 ±0.1 >M12 ±0.2 鑽孔, 魚眼孔公差 +0.1 -0.1 角度公差 ±0.5°	表面粗度 4Ra=S 一般表示 Ra 32-125 8.0-25 2.0-6.3 0.25-1.6 0.07-0.2	△ 29-06-11	271->272	detron	比例 SCALE	機型 MODEL	材質 MATERIAL	名稱 TITLE	料號 PART NO.		
			△ 20-04-11	馬達護罩修正;275->271		1=8	GX125P		外型圖			
			△ 24-01-11	取消HF73		角法 SKIAGRAPHY	用量 UNIT	備註 REMARKS	核準	審圖	繪圖	
			△ 07-01-11	圖面整理,本體進版		1/台						SHEET 1 OF 1
ITEM	DATE	ITEM DESCRIPTION										