

MAX. Loading Capacity	Vertical 100Kg Horizontal 250Kg
Allowable loading inertia	20.7 Kg.cm.s <sup>2</sup>
Indexing accuracy	15°
Repeatability	4°
Resolution	0.001°
Allowable cutting torque	55 kg-m
MAX. table speed	22.2 rpm
Servo motor type	FANUC 4i/8i
Transmission ratio	1:120
Clamping torque	70 kg-m
Drive pressure	50 kg/cm <sup>2</sup>

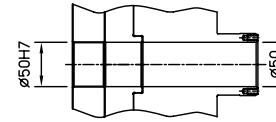

中心孔寸

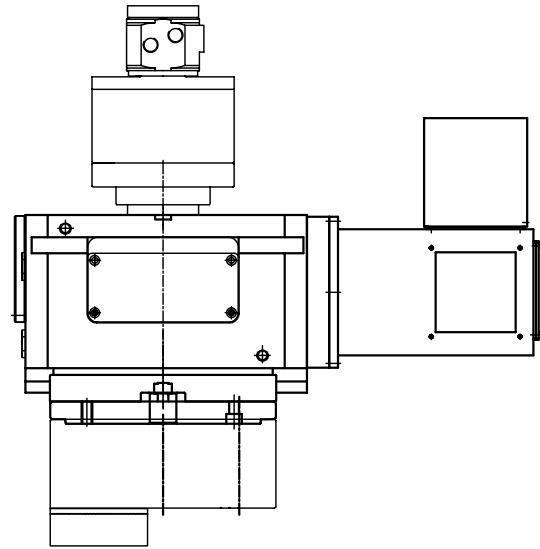
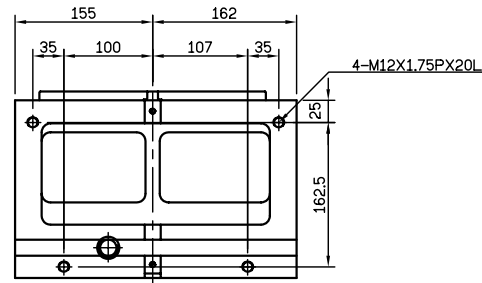
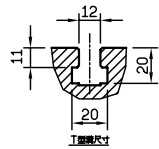
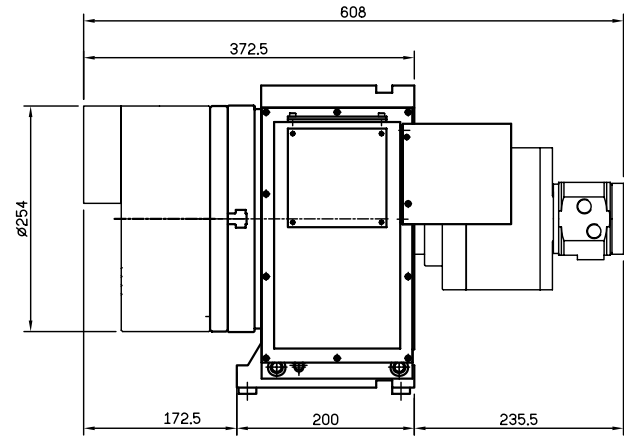
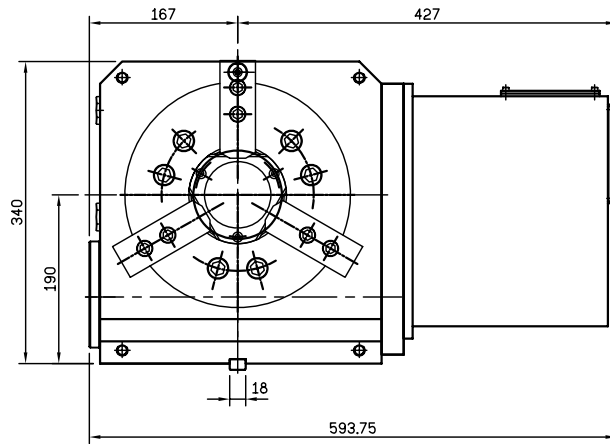

		detron		比例 SCALE	模型 MODEL	材質 MATERIAL	名稱 TITLE	圖號 DRAWING NO.
				1=3	GX255H		GX255H+10夾頭	
▲ 00'00'00		XXXXX		角註 SKIAGRAPHY	用途 UNIT	備註 REMARKS	校準	製圖
ITEM DATE	ITEM DESCRIPTION							SHEET OF A2