

最大工件負載 Max Loading Capacity	立式 Vertical 150kg 臥式 Horizontal 350kg	伺服馬達型式 Servo motor	A12i/B22is/HC-H202 HF203/204 SGMGH-20A	△
許容工件慣量 Allowable Loading Inertia	45.7 kg-cm-sec ²	減速比 Transmission ratio	1:120	
分割精度 Indexing accuracy	15"	剎車鎖緊力 Clamping torque	118 kg-m	
重複精度 Repeatability	6"	油壓剎車源 Hyd. pressure	50 kg/cm ²	
最小設定單位 Resolution	0.001"			
許容切削扭矩 Cutting torque	78 kg-m			
最高迴轉數 Max table speed	22.2 rpm			

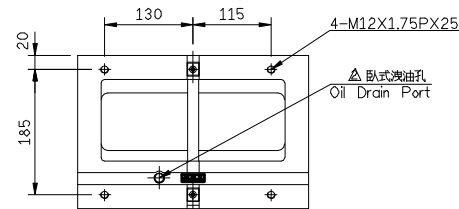
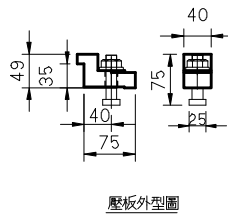
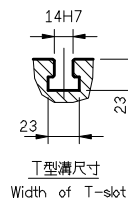
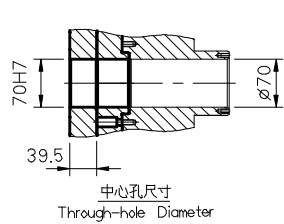
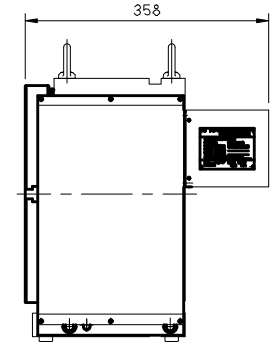
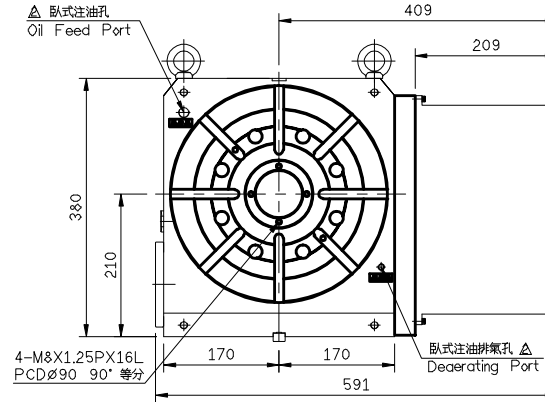
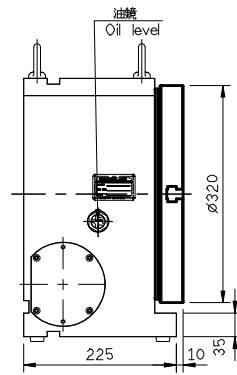
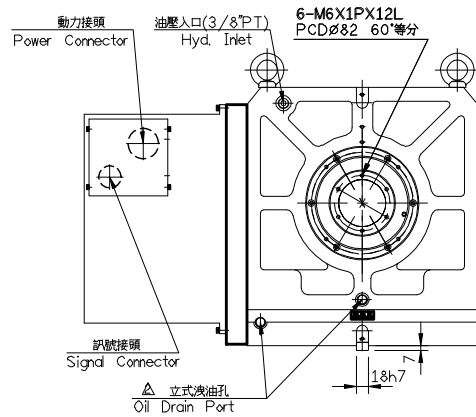
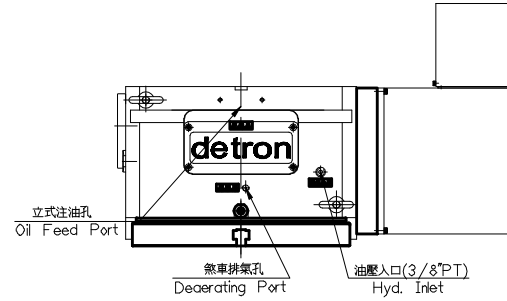

GX320H-A02

ITEM	DATE	ITEM DESCRIPTION	比例 SCALE	機型 MODEL	材質 MATERIAL	名稱 TITLE	料號 PART NO.	
△	24-01-11	取消HF353;B22i->B22is	1=8	GX320H		外型圖		
△	20-01-11	取消HA100N;增加SGMGH-20A	用量 UNIT	備註 REMARKS	核准	審圖	繪圖	
△	07-01-11	本繪圖版/圖面整理	1/台					
							SHEET 1 of 1	A3