

最大工件負載 Max Loading Capacity	立式 450kg Horizontal 800kg
許容工件慣量 Allowable Loading Inertia	405 kg-cm-sec ²
分容精度 Indexing accuracy	15°
重複精度 Repeatability	6°
最小設定單位 Resolution	0.001°
許容切削扭矩 Cutting torque	430 kg-m
最高迴轉數 Max table speed	11.1 rpm
伺服馬達型式 Servo motor	A22i/A22is/B22is HF353/SGMGH-30A
減速比 Transmission ratio	1:180
制動扭矩 Clamping torque	450 kg-m
油壓利車源 Hyd pressure	50 kg/cm ²

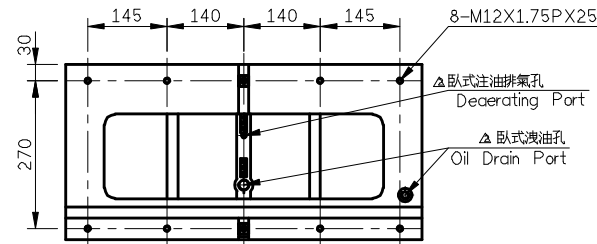
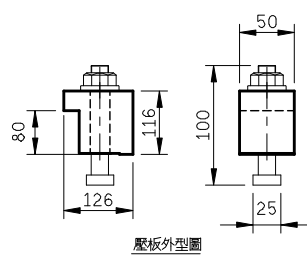
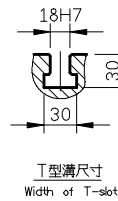
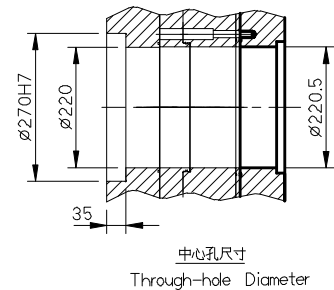
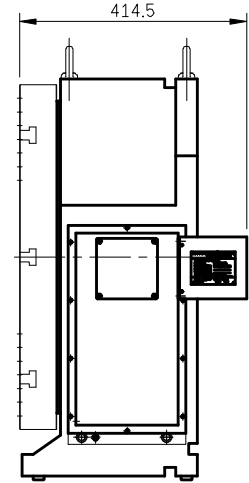
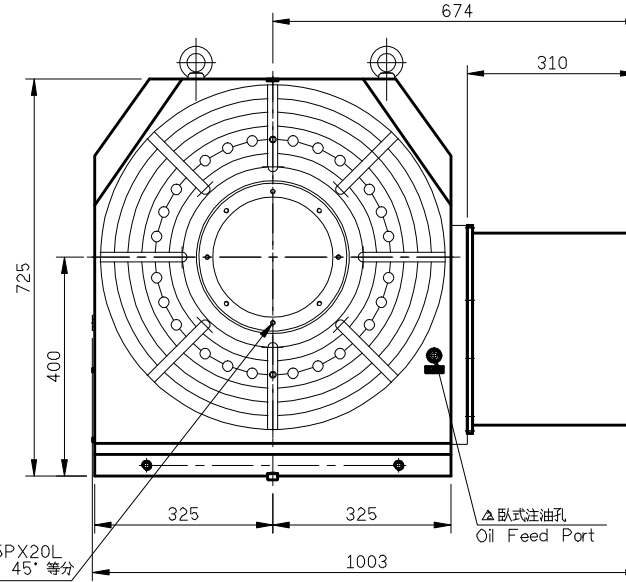
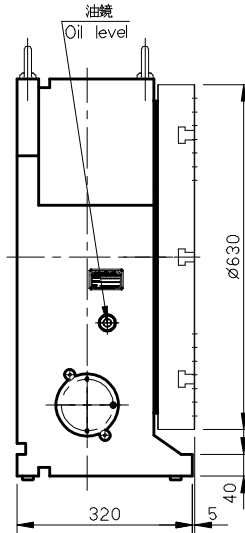
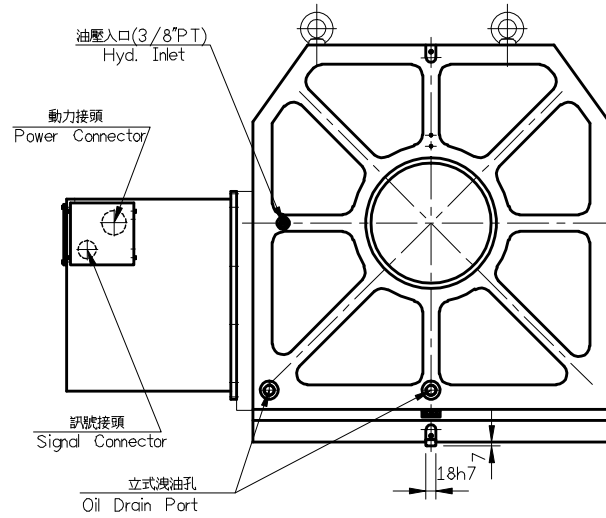
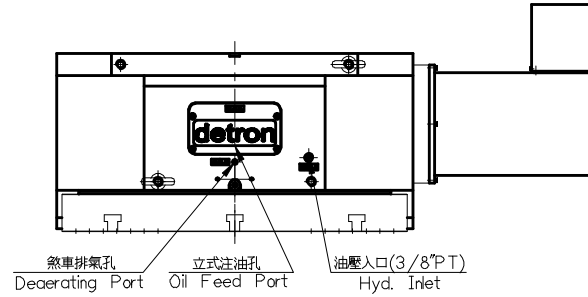

加工-公差	實際中心距公差	表面粗糙度	4R=5
<6	±0.05	<M12	±0.1
>6	±0.07	M12	±0.2
>20	±0.1	表面, 實際公差	±0.2-±0.5
>150	±0.2	±0.1	±0.5-±1.0
>115	±0.2	±0.1	±0.5-±1.6
>1000	±0.4	±0.1	±0.7-±1.2

		detron		比例 SCALE	模型 MODEL	材質 MATERIAL	名稱 TITLE	料號 PART NO.
				1=7	GX630H		外型圖	
20-01-11	取決A30s/A40s/SGMGH-40A	方法 SKIAGRAPHY	用 UNIT	備註 REMARKS	校準	穿通	穿通	
07-01-11	表面處理-本機加裝		1/台	退火處理				
ITEM DATE	ITEM DESCRIPTION							SHEET 1 OF 1

A
B
C
D
E
F
G
H
I
J

GX630H-A02