

1	2	3	4	5	6	7	8	9	10	11	12	13	14	15
工作台尺寸	500X500													
最大工件負載	600kg(平均負荷)													
中心孔	∅50H7													
最小設定單位	1°													
伺服馬達型式	[FANUC] α8i													
齒數比	1:144													
分度盤最大轉數	16.6r.p.m/min													
刹車鎖緊力	5600Kg													
油壓源壓力	50kg/cm <sup>2</sup>													
分割精度	±5"													
重複精度	±2"													
上枱面旋轉起伏	0.02mm													
上下平面平行度	0.02mm													
上枱面平面度	0.02mm													

確認用圖	
客戶確認用章	
核准	審核

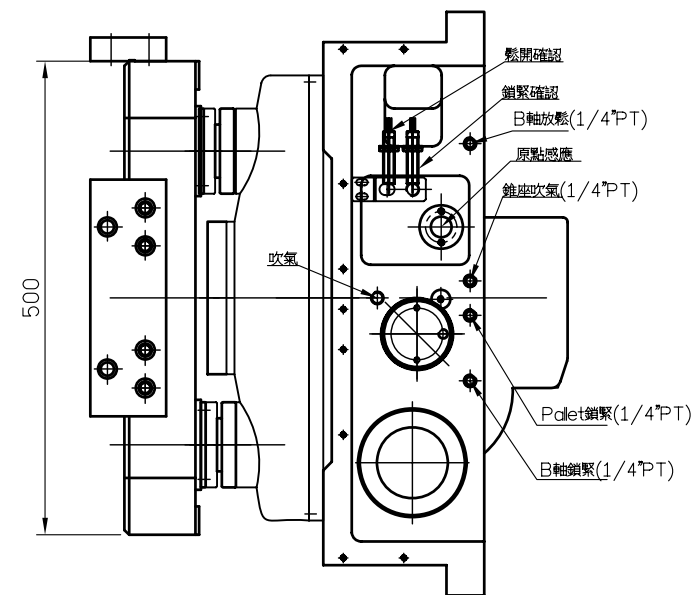
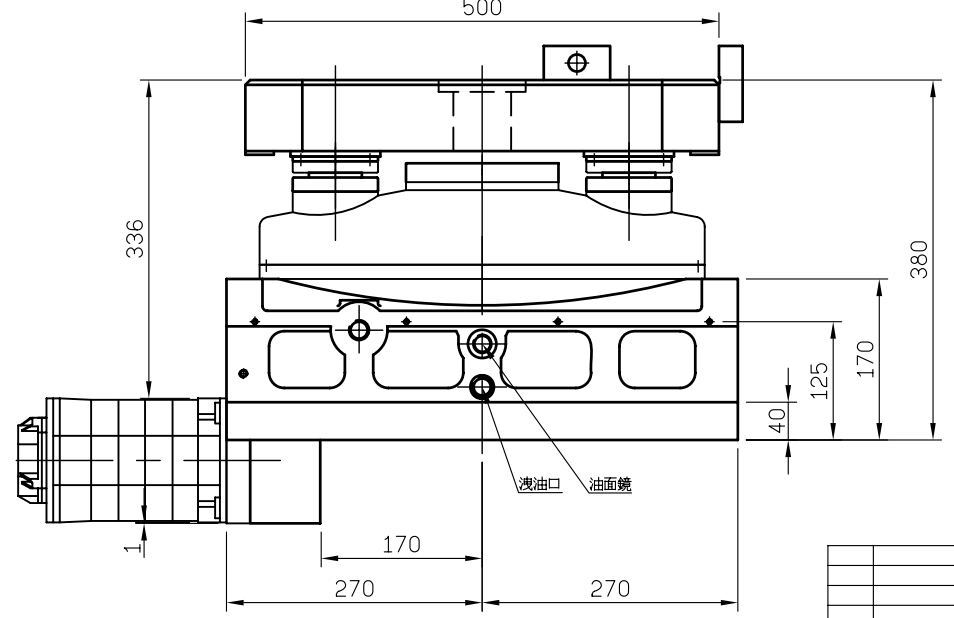
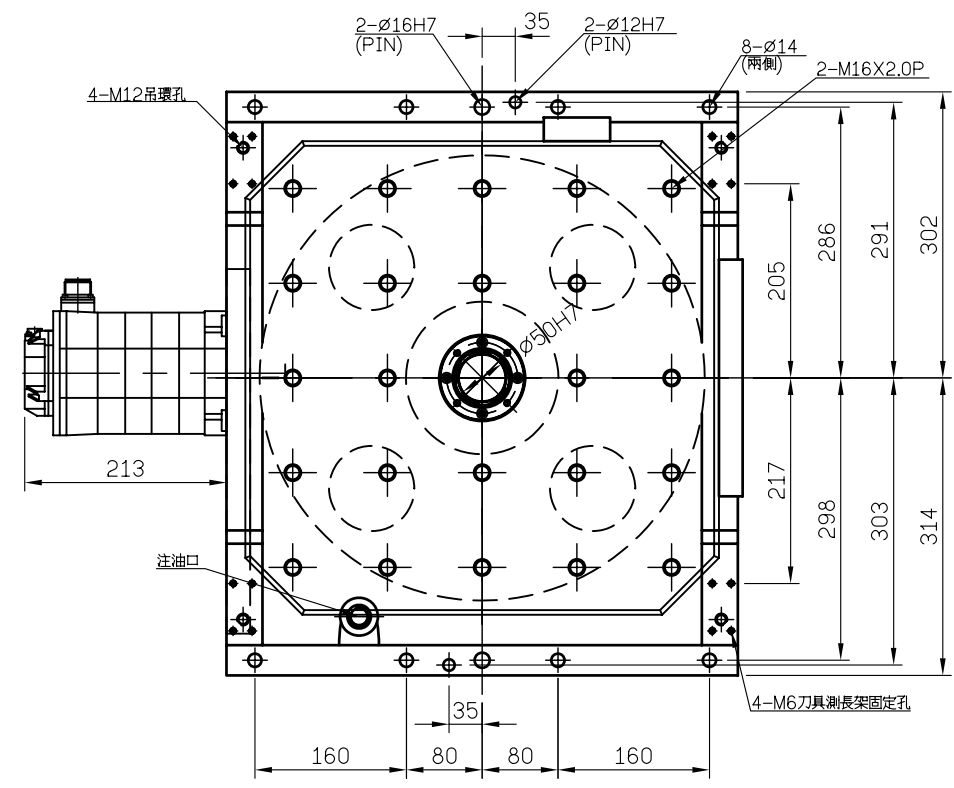
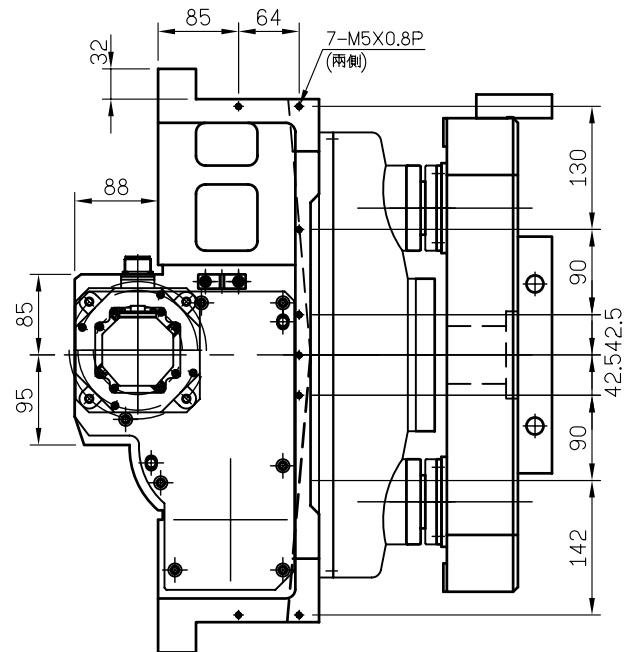

比例 SCALE	機型 MODEL	材質 MATERIAL	名稱 TITLE	圖號 DRAWING NO.
1=6	HH501T2		HH501外型圖	HH501HT2-LKM-FAA
角法 SKIAGRAPHY	用圖 UNIT	備註 REMARKS	核准	審圖
00'00'00	XXXXX			
ITEM DATE	ITEM DESCRIPTION			
				SHEET OF A2