

T Slot Size

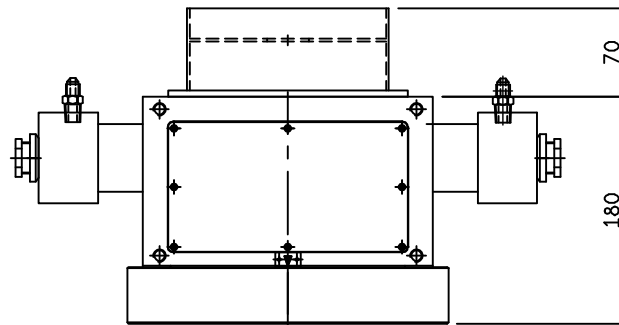

	A
3 Division	491
4 Division	333

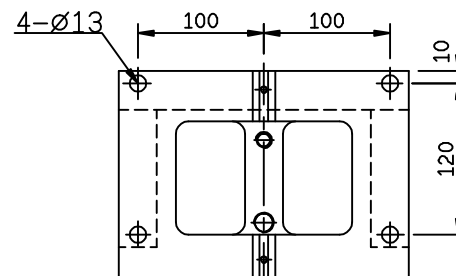
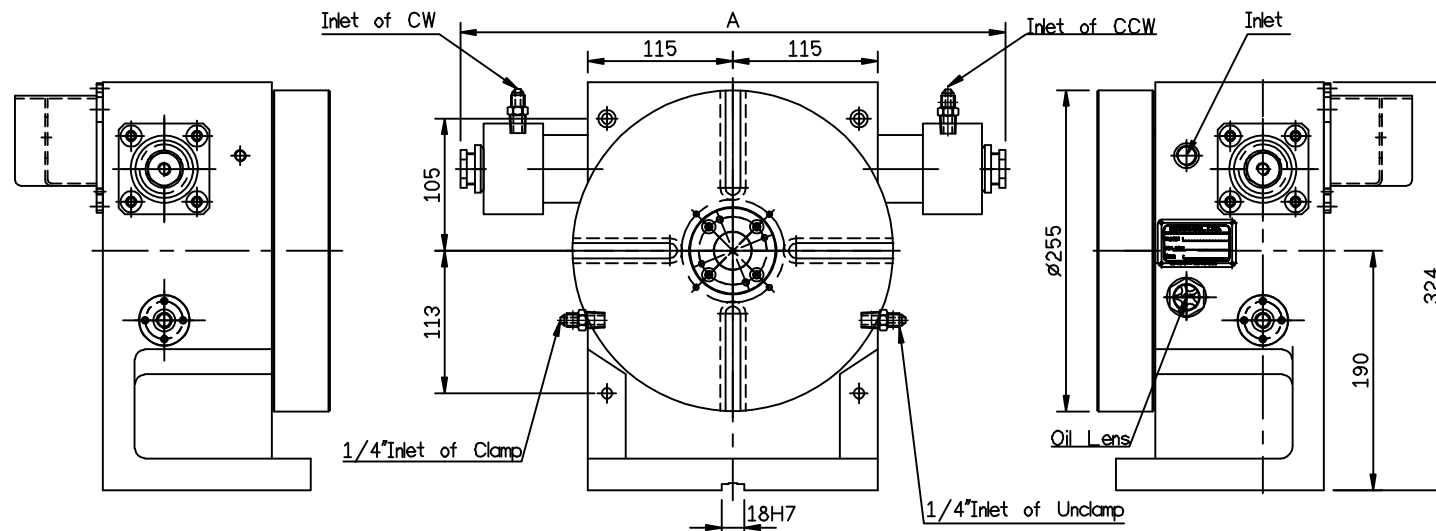

Work table diameter	ø255	
Height of table	Vertical	324mm
	Horizontal	180mm
Center bore diameter	ø30H7X29	
Through-hole diameter	ø27mm	
Division Number	4	
Rotation	CW./CCW	
Index orientation	3Pcs Coupling	
Division accuracy	±5°	
Max. pressure	35kg/cm ²	
Max. clamping torque	1400kg	
Allowable Loading capacity	Vertical	110 kg
	Horizontal	200 kg
Allowable inertia	35kg.cm.s	
Table Rotation torque	42kg.m	
Weight	65kg	
Connector	MS-3108A-2029PW	

		detron		比例 SCALE	機型 MODEL	材質 MATERIAL	名稱 TITLE	圖號 DRAWING NO.
				1=6	RX255H		RX255H外型圖	
				角法 SKIAGRAPHY	用量 UNIT	備註 REMARKS	核准	審圖 繪圖
				△ 00'00'00	XXXXX			
ITEM	DATE	ITEM DESCRIPTION		⊕ ⊖	1/台			SHEET 1 OF 1 A4